

ALL 32" OPEN AND ENCLOSED FLUME SLIDES ARE CONSTRUCTED OF LAMINATED FIBERGLASS REINFORCED MARINE GELCOAT SURFACE.

MATERIAL THICKNESS: 1/4"-3/8"

LEFT

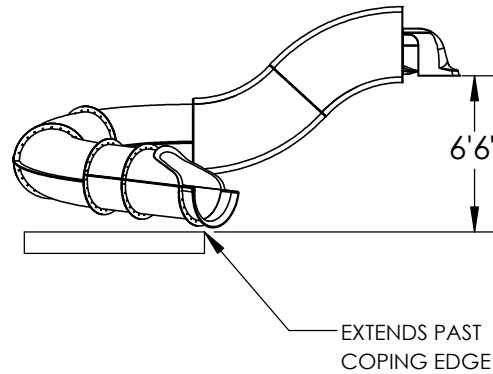

FRONT

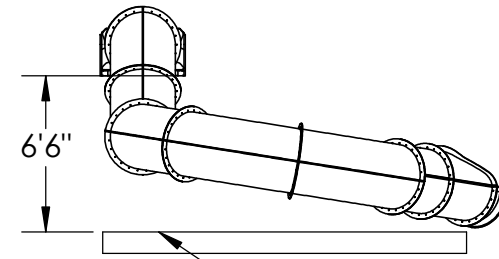

COPING LEVEL (0'-0") ALL ELEVATION DIMENSIONS ARE DERIVED FROM THIS LINE.

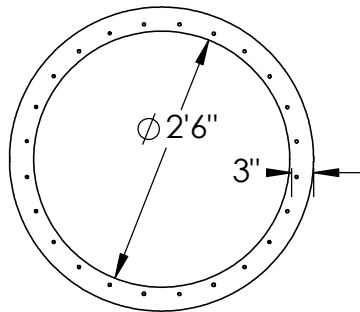

FLUME DIMENSIONS

ENTRY SUPPORT AND Ø 16" MIN PIERS (BY OTHERS) DEPTH DETERMINED BY LOCAL FROST DEPTH

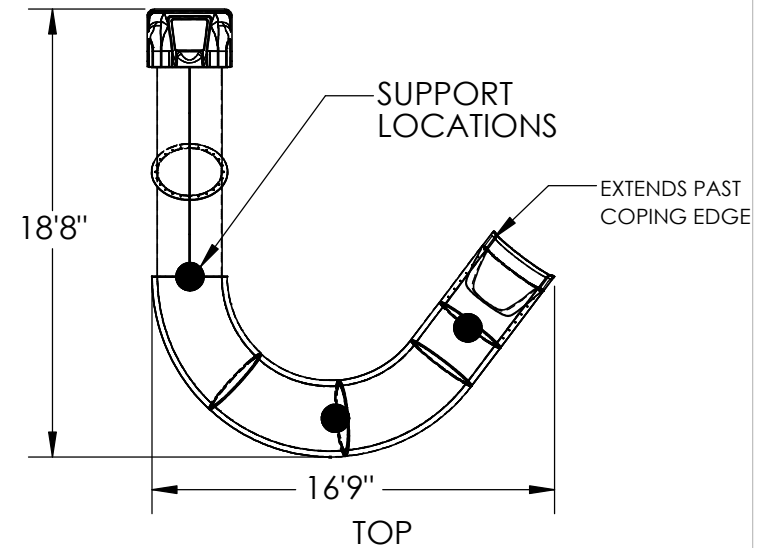

APPROVED BY: _____
DATE: _____

STEEL SUPPORTS: 3

FLUME TYPE	ENCLOSED
CL LENGTH	31.82'
ELEVATION	6'-6"
ENTRY ANGLE	N/A °
SLOPE	AVG 22%
FALL PER FOOT	AVG 2.5"
GPM REQUIRED	125-150
WATER DEPTH	4'-0" MINIMUM

TITLE:

RE32-31

SIZE

A

PRE-MODELED TUBE SLIDE

REV

PO Box 486 P: 731.632.1407
Adamsville, TN 38310 F: 731.632.3739

www.dolphinwaterslides.net
sales@dolphinwaterslides.net

SCALE: 1:96 - 1/8" = 1'

DRAWN B.Thomas 11/2/2

PROPRIETARY AND CONFIDENTIAL
THE INFORMATION CONTAINED IN THIS DRAWING IS THE SOLE PROPERTY OF DOLPHIN WATERSLIDES, INC. ANY REPRODUCTION IN PART OR AS A WHOLE WITHOUT THE WRITTEN PERMISSION OF DOLPHIN WATERSLIDES, INC IS PROHIBITED.