

FRONT

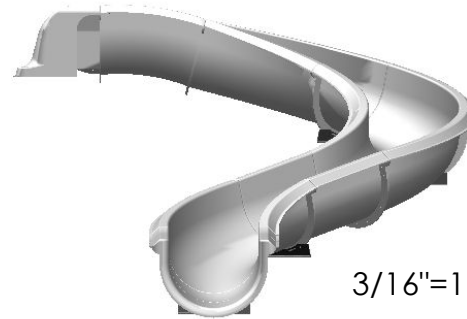

ALL 32" OPEN AND ENCLOSED FLUME SLIDES ARE CONSTRUCTED OF LAMINATED FIBERGLASS REINFORCED MARINE GELCOAT SURFACE.

MATERIAL THICKNESS: 1/4"-3/8"

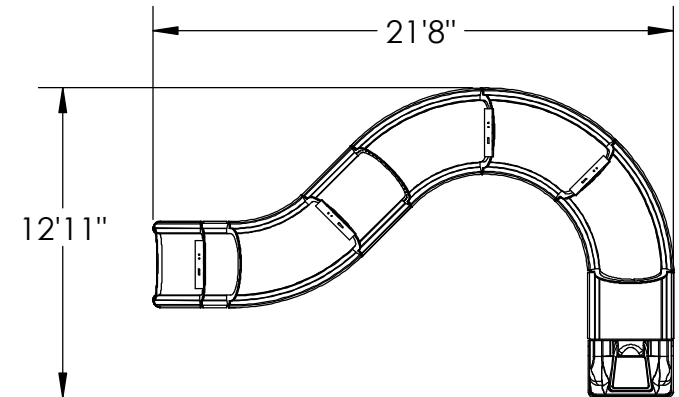
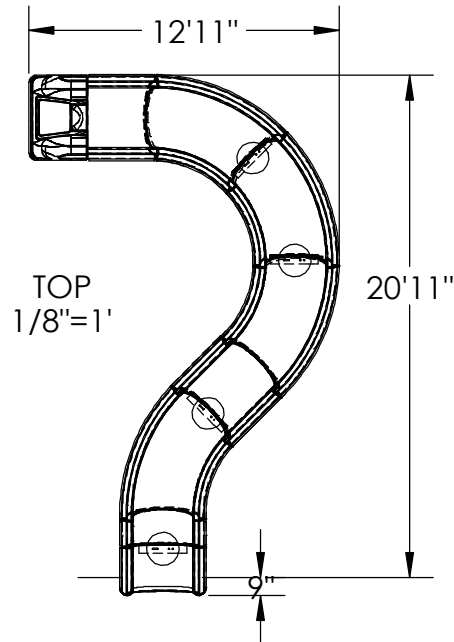

RB32-30B
1/8"=1'

STEEL SUPPORTS: 4

FLUME TYPE	32" OPEN
CL LENGTH	30.24'
ELEVATION	6'-7"
ENTRY ANGLE	15°
SLOPE	23.73%
FALL PER FOOT	2.85"
GPM REQUIRED	150-175
WATER DEPTH	4'-0" MINIMUM

TITLE: **MODEL RB32-30**

SIZE
A

PRE-DESIGN

REV



PO Box 486 P: 731.632.1407
Adamsville, TN 38310 F: 731.632.3739

www.dolphinwaterslides.net
sales@dolphinwaterslides.net

DRAWN B.Thomas 6/18/2010 REVISED 9/6/10 BY RRM

SCALE: 1:96 - 1/8" = 1'

PROPRIETARY AND CONFIDENTIAL
THE INFORMATION CONTAINED IN THIS DRAWING IS THE SOLE PROPERTY OF DOLPHIN WATERSLIDES, INC. ANY REPRODUCTION IN PART OR AS A WHOLE WITHOUT THE WRITTEN PERMISSION OF DOLPHIN WATERSLIDES, INC IS PROHIBITED.